

Архангельск (8182)63-90-72
Астана (7172)727-132
Астрахань (8512)99-46-04
Барнаул (3852)73-04-60
Белгород (4722)40-23-64
Брянск (4832)59-03-52
Владивосток (423)249-28-31
Волгоград (844)278-03-48
Вологда (8172)26-41-59
Воронеж (473)204-51-73
Екатеринбург (343)384-55-89
Иваново (4932)77-34-06

Ижевск (3412)26-03-58
Иркутск (395)279-98-46
Казань (843)206-01-48
Калининград (4012)72-03-81
Калуга (4842)92-23-67
Кемерово (3842)65-04-62
Киров (8332)68-02-04
Краснодар (861)203-40-90
Красноярск (391)204-63-61
Курск (4712)77-13-04
Липецк (4742)52-20-81
Киргизия (996)312-96-26-47

Магнитогорск (3519)55-03-13
Москва (495)268-04-70
Мурманск (8152)59-64-93
Набережные Челны (8552)20-53-41
Нижний Новгород (831)429-08-12
Новокузнецк (3843)20-46-81
Новосибирск (383)227-86-73
Омск (3812)21-46-40
Орел (4862)44-53-42
Оренбург (3532)37-68-04
Пенза (8412)22-31-16
Казахстан (772)734-952-31

Пермь (342)205-81-47
Россия (495)268-04-70
Ростов-на-Дону (863)308-18-15
Рязань (4912)46-61-64
Самара (846)206-03-16
Санкт-Петербург (812)309-46-40
Саратов (845)249-38-78
Севастополь (8692)22-31-93
Симферополь (3652)67-13-56
Смоленск (4812)29-41-54
Сочи (862)225-72-31
Ставрополь (8652)20-65-13

Сургут (3462)77-98-35
Тверь (4822)63-31-35
Томск (3822)98-41-53
Тула (4872)74-02-29
Тюмень (3452)66-21-18
Ульяновск (8422)24-23-59
Уфа (347)229-48-12
Хабаровск (4212)92-98-04
Челябинск (351)202-03-61
Череповец (8202)49-02-64
Ярославль (4852)69-52-93

<https://hoshizaki.nt-rt.ru/> || hzo@nt-rt.ru

SELF-CONTAINED CUBER
MACHINE A GLACONS AUTONOME
STECKERFERTIGER WÜRFELEISBEREITER
IJSBLOKJESMACHINE MET INGEBOUWDE OPSLAGBUNKER
MÁQUINA FABRICADORA DE HIELO INTEGRADA
FABBRICATORE DI GHIACCIO IN CUBETTI A RISERVA INCORPORATA

INSTRUCTION MANUAL

(original instructions)

NOTICE D'UTILISATION

(instructions traduites)

BEDIENUNGSANLEITUNG

(Übersetzung)

GEBRUIKSAANWIJZING

(vertaalde instructies)

MANUAL DE INSTRUCCIONES

(instrucciones traducidas)

MANUALE D'ISTRUZIONI

(traduzione)

IM-21CNE-HC
IM-30CNE-HC
IM-30CWNE-HC
IM-45CNE-HC
IM-45NE-HC
IM-45WNE-HC
IM-65NE-HC
IM-65WNE-HC
IM-100CNE-HC



IM-100NE-HC

HOSHIZAKI EUROPE LIMITED

Telford 70 Stafford Park 7, Telford, Shropshire TF3 3BQ UK

L1M036205 (101520)

ENGLISH	IMPORTANT SAFETY INFORMATION.....	1
	I. INSTALLATION INSTRUCTIONS.....	3
	1. CONSTRUCTION.....	3
	2. ACCESSORIES.....	3
	3. UNPACKING.....	4
	4. LOCATION.....	5
	5. INSTALLATION.....	6
	6. ELECTRICAL CONNECTIONS.....	6
	7. WATER SUPPLY AND DRAIN CONNECTIONS.....	6
	II. OPERATING INSTRUCTIONS.....	9
	1. START UP.....	9
	2. PREPARING THE ICEMAKER FOR LONG STORAGE.....	9
	III. MAINTENANCE.....	10
	1. CLEANING.....	10
	2. BEFORE CALLING FOR SERVICE.....	11
	3. DISPOSAL.....	12
	4. WARRANTY.....	12
	SPECIFICATIONS.....	13
FRANCAIS	INFORMATIONS DE SECURITE IMPORTANTES.....	15
	I. CONSIGNES D'INSTALLATION.....	17
	1. CONSTRUCTION.....	17
	2. ACCESSOIRES.....	17
	3. DEBALLAGE.....	18
	4. EMBLACEMENT.....	19
	5. INSTALLATION.....	20
	6. BRANCHEMENTS ELECTRIQUES.....	20
	7. BRANCHEMENTS D'ARRIVEE ET DE VIDANGE D'EAU.....	21
	II. CONSIGNES D'UTILISATION.....	23
	1. MISE EN MARCHÉ.....	24
	2. PREPARATION DU DISTRIBUTEUR DE GLACE EN VUE D'UN ENTREPOSAGE DE LONGUE DUREE.....	24
	III. ENTRETIEN.....	24
	1. NETTOYAGE.....	24
	2. AVANT D'APPELER UN REPARATEUR.....	25
	3. MISE AU REBUT.....	26
	4. GARANTIE.....	26
	SPECIFICATIONS.....	27
DEUTSCH	WICHTIGE SICHERHEITSHINWEISE.....	30
	I. INSTALLATIONSANLEITUNG.....	32
	1. KONSTRUKTION.....	32
	2. ZUBEHÖR.....	32
	3. AUSPACKEN.....	33
	4. AUFSTELLORT.....	34
	5. INSTALLATION.....	35
	6. ELEKTRISCHE ANSCHLÜSSE.....	35
	7. WASSERZUWASSERZULAUF- UND WASSERABFLUSSANSCHLÜSSE.....	36
	II. BEDIENUNGSANLEITUNG.....	38
	1. INBETRIEBNAHME.....	38
	2. MASSNAHMEN FÜR DIE LANGFRISTIGE LAGERUNG DES EISBEREITERS.....	39
	III. WARTUNG.....	39
	1. REINIGUNG.....	39
	2. VOR ANRUF DES KUNDENDIENSTES.....	40
	3. ENTSORGUNG.....	41
	4. GEWÄHRLEISTUNG.....	41
	TECHNISCHE DATEN.....	42

NEDERLANDS	BELANGRIJKE VEILIGHEIDSINFORMATIE	44
	I. INSTALLATIE-INSTRUCTIES.....	46
	1. CONSTRUCTIE.....	46
	2. TOEBEHOREN.....	46
	3. UITPAKKEN	47
	4. PLAATSING.....	48
	5. INSTALLATIE	49
	6. ELEKTRISCHE AANSLUITINGEN	49
	7. AANSLUITING VAN WATERTOEOVOER- EN WATERAFVOERLEIDINGEN	50
	II. BEDIENING.....	52
	1. OPSTARTEN.....	52
	2. DE IJSMAKER GEREEDMAKEN VOOR LANGDURIGE OPSLAG.....	53
	III. ONDERHOUD.....	53
	1. REINIGEN	53
	2. VOORDAT U BELT VOOR SERVICE.....	54
	3. VERWIJDERING	55
	4. GARANTIE	55
	SPECIFICATIES	56
ESPAÑOL	INFORMACIÓN IMPORTANTE DE SEGURIDAD	58
	I. INSTRUCCIONES DE INSTALACIÓN.....	60
	1. CONSTRUCCIÓN	60
	2. ACCESORIOS.....	60
	3. DESEMBALAJE.....	61
	4. UBICACIÓN.....	62
	5. INSTALACIÓN.....	63
	6. CONEXIONES ELÉCTRICAS	63
	7. SUMINISTRO DE AGUA Y CONEXIONES DE DRENAJE.....	64
	II. INSTRUCCIONES DE UTILIZACIÓN	66
	1. PUESTA EN MARCHA.....	66
	2. PREPARACIÓN DE LA MÁQUINA DE HIELO PARA UN ALMACENAMIENTO PROLONGADO.....	67
	III. MANTENIMIENTO	67
	1. LIMPIEZA	67
	2. ANTES DE LLAMAR AL SERVICIO TÉCNICO.....	68
	3. ELIMINACIÓN	69
	4. GARANTÍA	69
	ESPECIFICACIONES.....	70
ITALIANO	INFORMAZIONI IMPORTANTI SULLA SICUREZZA.....	72
	I. ISTRUZIONI PER L'INSTALLAZIONE.....	74
	1. COMPONENTI	74
	2. ACCESSORI.....	74
	3. DISIMBALLAGGIO	75
	4. UBICAZIONE.....	76
	5. INSTALLAZIONE.....	77
	6. COLLEGAMENTI ELETTRICI	77
	7. COLLEGAMENTO DI ALIMENTAZIONE DELL'ACQUA E COLLEGAMENTO DI SCARICO ..	78
	II. ISTRUZIONI DI FUNZIONAMENTO	80
	1. AVVIO.....	80
	2. PREPARATIVI PER IL'IMMAGAZZINAGGIOL DELLA MACCHINA A LUNGO TERMINE	81
	III. MANUTENZIONE.....	81
	1. PULIZIA	81
	2. PRIMA DI RIVOLGERSI ALL'ASSISTENZA	82
	3. SMALTIMENTO.....	83
	4. GARANZIA	83
	SPECIFICHE	84

IMPORTANT SAFETY INFORMATION

Throughout this manual, notices appear to bring your attention to situations which could result in death, serious injury, or damage to the unit.

▲WARNING	Indicates a hazardous situation which, if not avoided, could result in death or serious injury.
▲CAUTION	Indicates a hazardous situation which, if not avoided, could result in minor or moderate injury.
NOTICE	Indicates a hazardous situation which, if not avoided, could result in damage to the unit.
▲HYGIENE	Indicates important precautions for hygiene and food safety.
IMPORTANT	Indicates important information about the use and care of the unit.

This icemaker uses HFC-free refrigerant (propane) that is a non-ozone-depleting and environmentally sustainable material having very low global warming potential.

▲WARNING	
This icemaker contains flammable refrigerant in its cooling unit; installation, handling, servicing and disposal must therefore only be carried out by authorized technicians.	
The refrigerant contained in this icemaker is flammable and sealed in the refrigeration system. Although the refrigerant does not leak out under normal usage, take utmost care when handling this icemaker so as not to cause any damages to the system.	
In the case of accidental damage to the refrigeration system causing refrigerant leak:	
<ul style="list-style-type: none"> * Do not create a source of ignition in the area. * Do not operate electrical switches or plugs in the area. * Do not use naked flame. * Immediately ventilate the area by opening doors and/or windows. * Call service engineer. 	
IMPORTANT	
This booklet is an integral and essential part of the product and should be kept and preserved by the user.	
Please read carefully the guidelines and warnings contained herein as they are intended to provide the installer/user with essential information for the proper installation and the continued safe use and maintenance of the product.	
Please preserve this booklet for any further consultation that may be necessary.	

⚠WARNING

This is a commercial icemaker, and should be destined only to be used for the purpose for which it has been expressly designed.

Any other use should be considered improper and therefore dangerous. The manufacturer will not be held liable or responsible for any damage caused by improper, incorrect and unreasonable use.

The installation, and relocation if necessary, must be carried out by qualified personnel, in accordance with current regulations, according to the manufacturer's instructions.

Keep ventilation openings, in the appliance enclosure or in the built-in structure, clear of obstruction.

Do not use mechanical devices or other means to accelerate the defrosting process, other than those recommended by the manufacturer.

The use of any electrical appliance involves the observance of some fundamental rules. In particular:

- * Instances of high humidity and moisture increase the risk of electrical short circuits and potential electrical shocks. If in doubt, disconnect the icemaker.
- * Do not damage the power cord or pull it in order to disconnect the icemaker from the electrical supply network.
- * If the supply cord is damaged, it must be replaced by a replacement cord available from Hoshizaki Parts/Service Centres.
- * Do not touch the electrical parts or operate the switches with damp hands.
- * This appliance is not intended for use by persons (including children) with reduced physical, sensory or mental capabilities, or lack of experience and knowledge, it can however be used by children aged from 8 years and above and persons with reduced physical, sensory or mental capabilities, or lack of experience and knowledge providing they have been given supervision or instruction concerning use of the appliance by a person responsible for their safety.
- * Children shall not play with the appliance.
- * Cleaning and user maintenance shall not be made by children without supervision.
- * Do not attempt to modify the icemaker. Only qualified personnel may disassemble or repair the appliance.

I. INSTALLATION INSTRUCTIONS

1. CONSTRUCTION

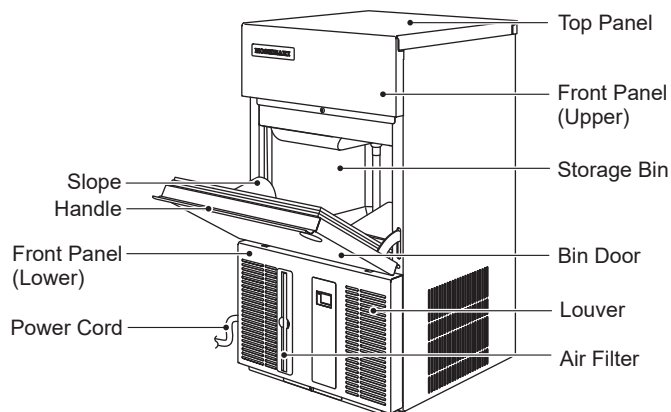

[IM-21CNE-HC, 30CNE/CWNE-HC]

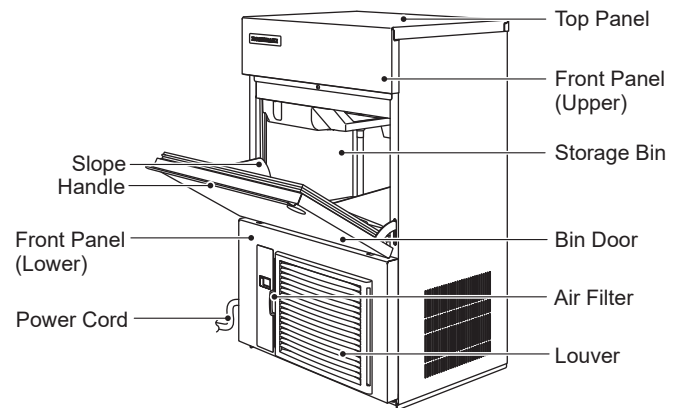

[IM-45NE/WNE-HC, 65NE/WNE-HC, 100NE/WNE-HC, 130NE/WNE-HC]

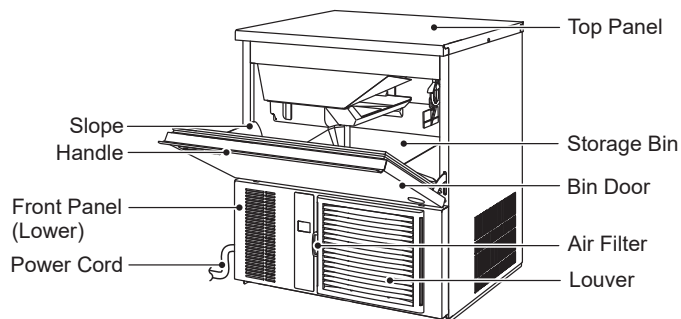

[IM-45CNE-HC]

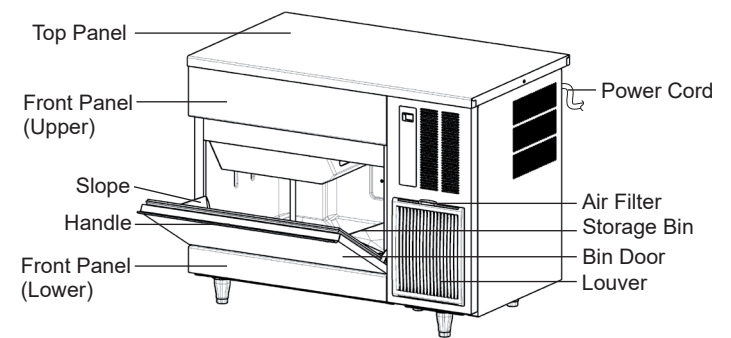

[IM-100CNE-HC]

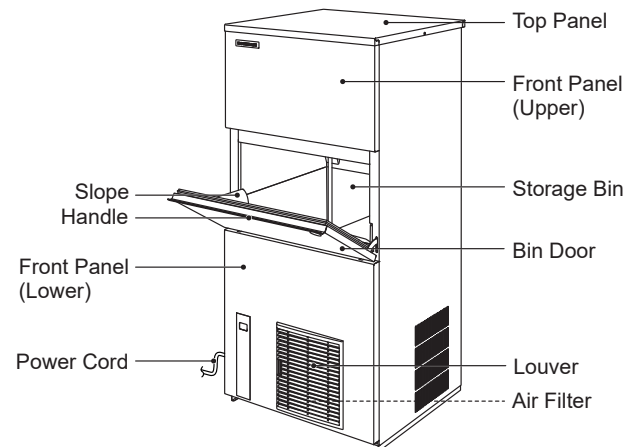

[IM-240NE/WNE-HC]

2. ACCESSORIES

	IM-21CNE-HC	IM-30CNE-HC IM-45CNE-HC IM-45NE-HC IM-65NE-HC IM-100NE-HC IM-130NE-HC IM-240NE-HC	IM-100CNE-HC	IM-30CWNE-HC IM-45WNE-HC IM-65WNE-HC IM-100WNE-HC IM-130WNE-HC IM-240WNE-HC
CD	1	1	1	1
Scoop	1	1	1	1
Inlet Hose	1	1	1	2
Outlet Hose	1	1	1	2
1/2-3/4 Nipple	-	-	-	2
Leg	-	4	5	4
Connector Cover	1	1	1	1
3/4-3/4 Nipple	-	-	1	-

ENGLISH



CD



Scoop



Inlet Hose



Outlet Hose



3/4-3/4
Nipple



1/2-3/4
Nipple



Leg

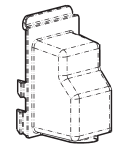

Connector Cover

3. UNPACKING

⚠ WARNING

Children should not be allowed in reach of the packaging elements (plastic bags and expanded polystyrene) as they are potential sources of danger.

⚠ CAUTION

Do not lift or manoeuvre the carton by using the shipping bands.

When moving the unit by hand, hold the unit bottom.

Always wear protective gloves when carrying the unit.

When handling the carton or the unpacked unit, work in pairs to prevent injury.

NOTICE

Remove shipping carton, tape(s) and packing. If packing material is left in the icemaker, it will not work properly.

- 1) After removing the packaging, make sure that the icemaker is in good condition. If in doubt, please do not use the icemaker but apply to professionally qualified personnel.
- 2) Remove the shipping tape holding the door and front panel.
- 3) Remove the protective plastic film from the exterior. If the icemaker is exposed to the sun or to heat, remove the film after the icemaker cools.
- 4) Remove the package of accessories. Check the contents according to "2. ACCESSORIES".
- 5) Remove the shipping tape holding the bin control switch by opening the bin door and reaching in.

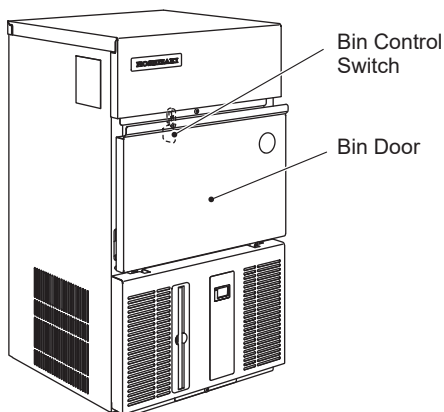

[IM-21CNE-HC, 30CNE/CWNE-HC]

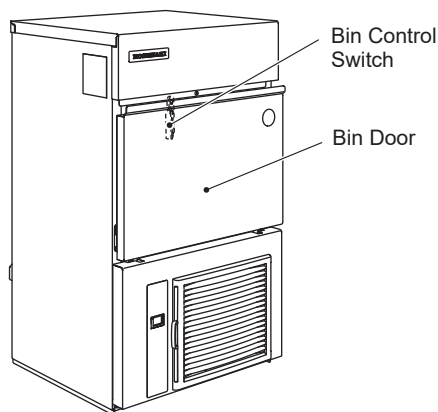

[IM-45NE/WNE-HC, 65NE/WNE-HC,
100NE/WNE-HC, 130NE/WNE-HC]

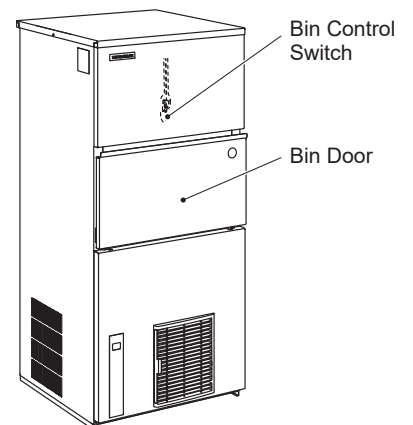

[IM-240NE/WNE-HC]

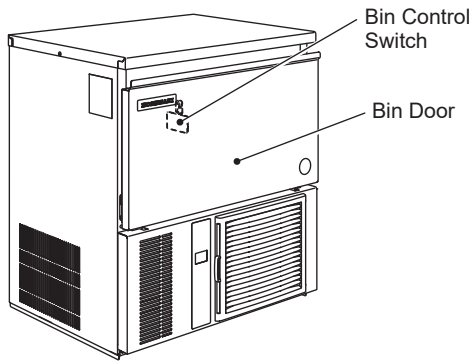

[IM-45CNE-HC]

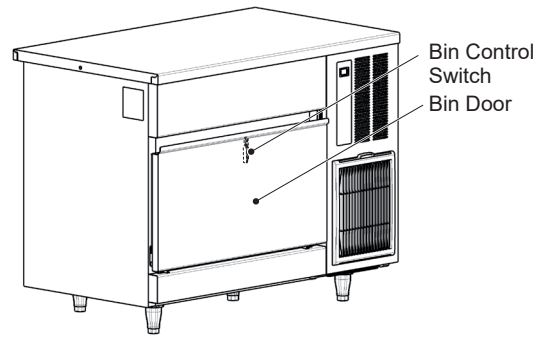

[IM-100CNE-HC]

4. LOCATION

⚠ WARNING

This icemaker is not intended for outdoor use.

The icemaker should not be located next to ovens, grills or other high heat producing equipment.

This appliance is not suitable for installation in an area where a water jet could be used.

⚠ CAUTION

The location should provide a firm and level foundation for the icemaker.

NOTICE

Do not place anything on top of the icemaker or in front of the louver.

IMPORTANT

Normal operating ambient temperature should be within 1°C to 40°C. Water connection is cold water only. Operation of the icemaker, for extended periods, outside of these normal temperature ranges may affect production capacity.

Allow the clearance specified below for proper air circulation and ease of maintenance and/or service should they be required.

[IM-21CNE-HC, 30CNE/CWNE-HC, 45CNE-HC, 240WNE-HC]

[IM-240NE-HC]

* No clearance required on sides

Side View

* No clearance required on sides

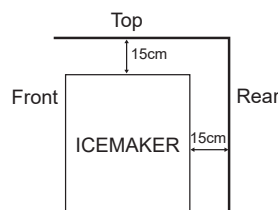

Side View

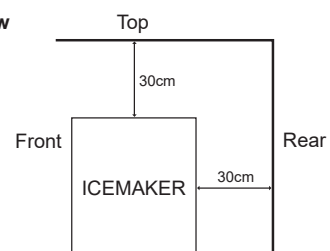

[IM-45NE/WNE-HC, 65NE/WNE-HC, 100CNE-HC, 100NE/WNE-HC, 130NE/WNE-HC]

Top View

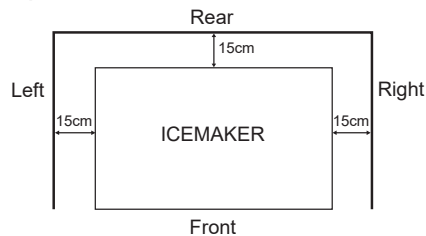

Side View

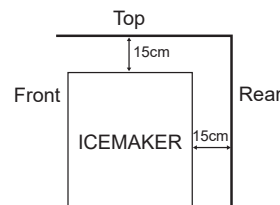

In some high humidity environments, condensation may form inside the machine and drip onto the floor. Do not install where the floor can be affected by water.

Avoid prolonged exposure of the appliance to direct sunlight.

ENGLISH

5. INSTALLATION

⚠ CAUTION

Incorrect installation can cause harm to people, animals or other items, for which the manufacturer cannot be held responsible.

* Place the icemaker in the selected permanent site.

[Except IM-21CNE-HC]

* When attaching the adjustable legs (accessory), level the unit in both the left-to-right and front-to-rear directions.

6. ELECTRICAL CONNECTIONS

⚠ WARNING

THIS APPLIANCE MUST BE EARTHED

This icemaker requires an earth that meets the national and local electrical code requirements.

To prevent possible severe electrical shock to individuals or extensive damage to the unit, install a proper earth wire to the icemaker.

Disconnect the main power supply before any maintenance, repairs or cleaning is undertaken.

* This appliance requires a separate 220 - 240VAC, 10A [IM-21CNE-HC, 30CNE/CWNE-HC, 45CNE/NE/WNE-HC, 65NE/WNE-HC, 100CNE/NE/WNE-HC, 130NE/WNE-HC] / 13A [IM-240NE/WNE-HC] supply. The electrical supply must be protected by a suitable circuit breaker.

* The main control box fuse is rated at 5A and should only be replaced by a qualified service engineer.

* Usually an electrical permit and services of a licensed electrician are required.

For the U.K. and the Republic of Ireland only

* The wires in the mains lead are coloured in accordance with the following code:

Green & Yellow = Earth

Blue = Neutral

Brown = Live

As the colours of the wire in the mains lead of this appliance may not correspond with the coloured markings identifying the terminals in your plug, proceed as follows:

The wire which is coloured Green-and-Yellow must be connected to the terminal in the plug which is marked with the letter E or by the symbol \perp or coloured Green or Green-and-Yellow. The wire which is coloured Blue must be connected to the terminal which is marked with the letter N or coloured Black. The wire which is coloured Brown must be connected to the terminal which is marked with the letter L or coloured Red.

* Should the socket outlets in the installation site not be suitable for the plug supplied with your product, the plug must be removed (cut off if it is moulded on plug) and an appropriate plug fitted.

If the non-rewirable plug has been cut from the power supply cord, it must be disposed of. There should be no attempt to reuse it. Inserting such a plug into a socket elsewhere presents a serious risk of electrical shock.

* The non-rewirable plug must never be used without a fuse cover being fitted.

The correct replacement for the detachable fuse cover is identifiable from the manufacturer's reference number stamped on the plug.

Supply of replacement fuse covers can be obtained from Hoshizaki Parts/Service Centres.

Fuses should be rated at 13A and approved to BS 1362.

7. WATER SUPPLY AND DRAIN CONNECTIONS

⚠ WARNING

Connect to potable cold water supply only.

- * The connections to the mains water supply must be made in accordance with the countries' current requirements of the Water Supply or Water Fittings Regulations.
- * Icemaking water must be potable water. Where scaling can be caused by water quality:
 - Installation of an external filter or softener is recommended. Contact your local water treatment professional or Hoshizaki service agent.
 - Change to the "full drain flush" mode is recommended. Contact your local Hoshizaki service agent.
- * Water supply pressure should be minimum 0.07 MPa (0.7 bar) and maximum 0.8 MPa (8 bar). If the pressure exceeds 0.8 MPa (8 bar), use a proper pressure reducing valve. Do NOT throttle back the supply tap.
- * A plumbing permit and services of a licensed plumber may be required in some areas.
- * The icemaker drain is gravity flow, so ensure drain hose has an adequate pitch or fall.
- * Drain lines should not be installed directly to the sewer system. A vertical air gap of a minimum of 5 cm should be between the end of the drain hoses from the icemaker and the floor drain.

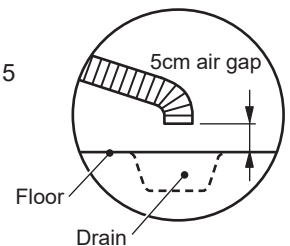

- * To prevent a backflow into the storage bin, the outlet hose must be laid as shown.

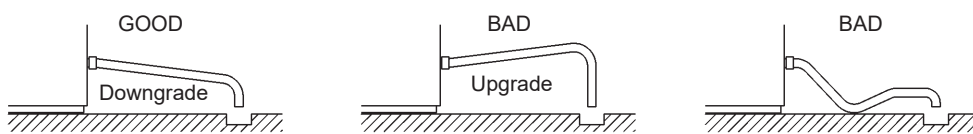

- * On water-cooled model, a back flow preventer may be required in the cooling water circuit.
- * Be sure to use the new hose-sets supplied with the appliance. Do not reuse any old hose-sets.

[Air-Cooled Model]

- 1) Attach the angled end of flexible inlet hose (accessory) to the G3/4 fitting on the rear of the icemaker as indicated, ensuring rubber sealing washer is correctly positioned. Hand tighten sufficiently to provide leak free joint.
- 2) Attach the other end of inlet hose to the water tap, noting washer is correctly positioned before hand tightening as above. It is a wise precaution to have a stop valve within easy reach.
- 3) [Except IM-100CNE-HC]
Hand tighten grey flexible outlet hose (accessory) onto the R3/4 fitting on the rear of the icemaker as indicated, ensuring rubber washer is correctly positioned to obtain a leak free joint. The hose can be cut to length as necessary to suit position of main drain.

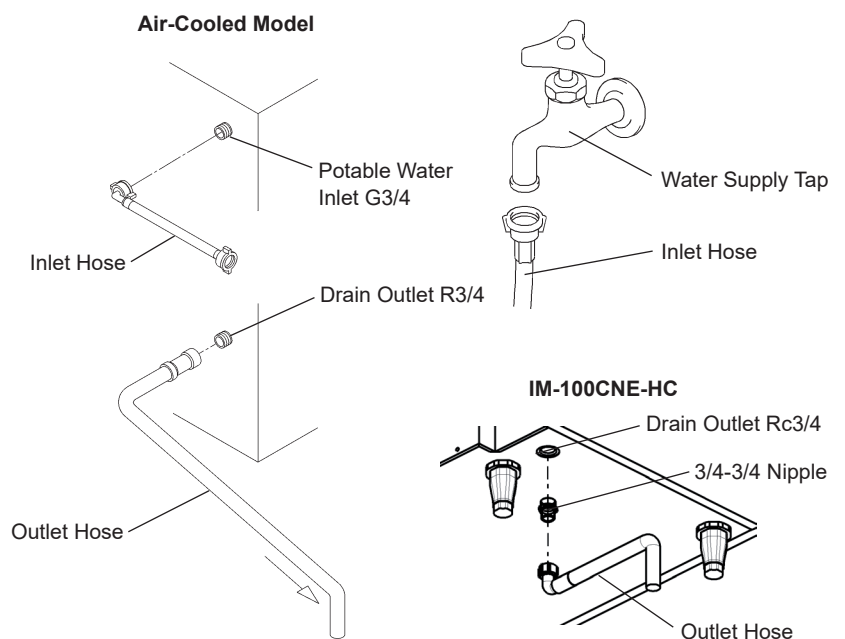

[IM-100CNE-HC]

By means of a suitable spanner or wrench, tighten the 3/4-3/4 nipple (accessory) into the Rc3/4 fitting on the bottom of the icemaker as indicated. P.T.F.E. tape and/or a suitable sealing compound should be used to obtain a leak free joint.

Note: Jointing compounds should be approved and suitable for potable water use.

Hand tighten grey flexible outlet hose (accessory) onto the 3/4-3/4 nipple as indicated, ensuring rubber washer is correctly positioned to obtain a leak free joint. The hose can be cut to length as necessary to suit position of main drain.

ENGLISH

[Water-Cooled Model]

* Hoshizaki recommends that the water-cooled condenser should be connected to a closed circuit recirculating type cooling system utilizing a tower, water chiller or similar. Water make up should be via a ball valve/break tank arrangement.

* Whilst connecting a water-cooled condenser to a mains water (potable) supply will not affect the performance of the machine, it will most certainly cause a high use/waste of a valuable resource and is not recommended.

* The services of a licensed or coded plumber should be used to ensure a correct installation.

* The connections should be made properly in compliance with the applicable national or local regulations.

[a] Standard connections according to WRAS regulations in U.K.

* When selecting a cooling tower, refer to the following peak values of heat flow in the condenser:

Model IM-30CW/45W:	295-760W
IM-65W:	875W
IM-100/130W:	1165W
IM-240W:	5235W

* Pipes between the cooling tower and the icemaker should be at least 20 mm DIA to reduce pressure loss, even though the icemaker fittings are 13 mm DIA.

* Pressure loss in the water circuit inside the unit will be 5 to 6 m when the cooling water flows at the ratio of 4 to 5 lit/min.

* Select a circulating pump referring to the above values of heat flow.

* Do not use a cascade pump, or the water regulator will vary the flow and stop it during the defrost cycle.

[Icemaker Connections]

1) Attach the angled end of flexible inlet hose (accessory) to the G3/4 fitting on the rear of the icemaker as indicated, ensuring rubber sealing washer is correctly positioned. Hand tighten sufficiently to provide leak free joint.

2) Attach the other end of inlet hose to the water tap, noting washer is correctly positioned before hand tightening as above.

Note: If filtration or treatment is used, ensure icemaker section only is on treated water supply, not the condenser.

3) Attach grey flexible outlet hose (accessory) to the R3/4 fitting on the rear of the icemaker as indicated, confirming fitment of rubber washer before finally hand tightening the joint. The hose can be cut to length as necessary to suit position of main drain.

4) By means of a suitable spanner or wrench, tighten the 1/2-3/4 nipples (accessory) into the Rc1/2 fittings on the rear of the icemaker as indicated. P.T.F.E. tape and/or a suitable sealing compound should be used to obtain a leak free joint.

Note: Jointing compounds should be approved and suitable for potable water use.

5) Connect the condenser cooling circuit to the free end of 1/2-3/4 nipples as indicated using a suitable rigid type pipe.

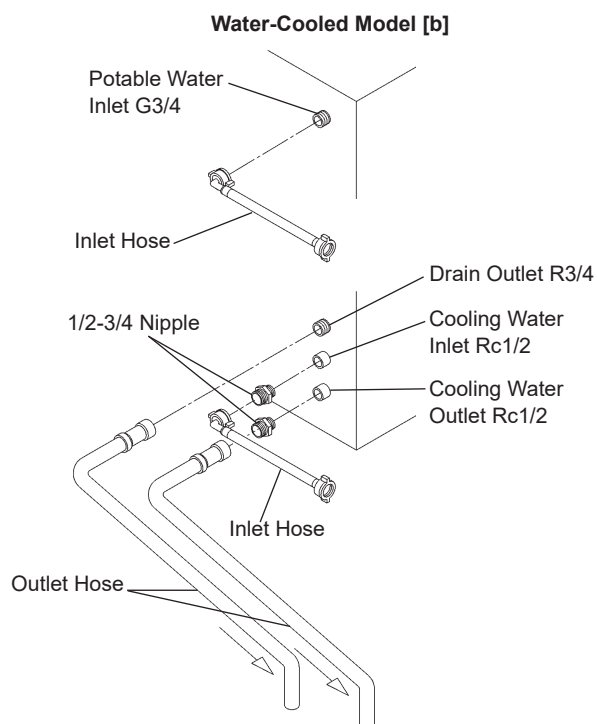
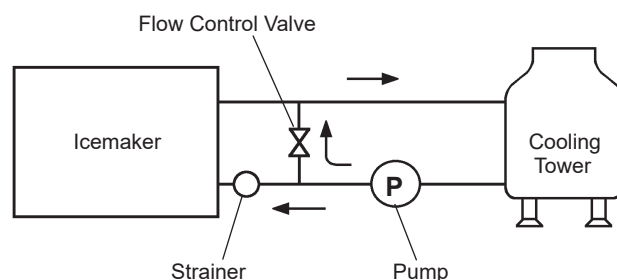
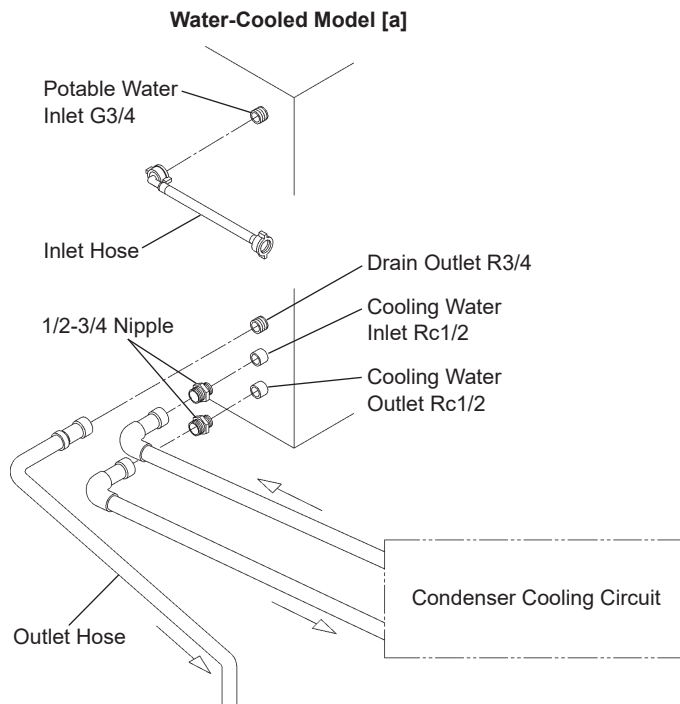

[b] Connections according to regulations other than WRAS by utilising accessory hoses

- 1) Follow the instructions from 1) to 4) in [a] above.
- 2) For condenser connections, use supplied accessory hoses and make the same connections as 1) to 3) in [a] above to the free end of 1/2-3/4 nipples as indicated.

II. OPERATING INSTRUCTIONS

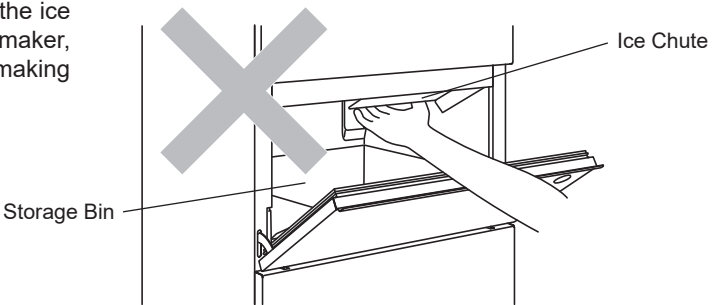
⚠ CAUTION	
<p>Do not put your hands into the back of the storage bin or the ice chute on top of the storage bin. Ice may drop off the icemaker, a hard block of ice may suddenly break down, or the icemaking mechanism may suddenly move, resulting in injury.</p>	

NOTICE
<p>All parts are factory-adjusted. Improper adjustments may result in failure.</p>
<p>If the unit is turned off, wait for at least 3 minutes before restarting the icemaker to prevent damage to the compressor.</p>

⚠ HYGIENE
<p>This icemaker is designed to produce edible ice. To keep the icemaker hygienic:</p> <ul style="list-style-type: none"> * Wash your hands before removing ice. Use the plastic scoop provided (accessory). * The storage bin is for ice use only. Do not store anything else in the bin nor use other electrical appliances in the bin. * Clean the storage bin before use (see "III. 1. CLEANING"). * Keep the scoop clean. Clean it by using a neutral cleaner and rinse thoroughly. * Close the door after removing ice to prevent entrance of dirt, dust or insects into the storage bin.

1. START UP

The installer will normally commission the icemaker to start the automatic icemaking process. To ensure continuous operation, make sure that:

- * The water supply tap is on, and
- * The icemaker is connected to the power supply.

2. PREPARING THE ICEMAKER FOR LONG STORAGE

NOTICE
<p>This icemaker will not work at subfreezing temperatures. To prevent damage to the water supply line, drain the icemaker when air temperature is below zero.</p>

⚠ HYGIENE
<p>When shutting down the icemaker for two or more days, drain the icemaker to prevent contamination in the water circuit.</p>

- 1) Unplug the icemaker or disconnect the power supply.
- 2) Close the water supply tap, and remove the inlet hose.
- 3) Remove all ice from the storage bin, and clean the bin.
- 4) Ask for draining of the icemaker by professional qualified personnel.

III. MAINTENANCE

1. CLEANING

⚠ WARNING

Before carrying out any cleaning or maintenance operations, unplug the icemaker from the electrical supply network.

This appliance must not be cleaned by use of a water jet.

⚠ CAUTION

When using a neutral cleaner or sodium hypochlorite, thoroughly read and understand the instructions provided to prevent potential health problems.

NOTICE

Ask a trained service person to clean and sanitise the icemaker water system at least twice a year and to check and clean the condenser at least once a year.

To prevent possible damage, do not clean the plastic parts with water above 40°C or in a dishwasher.

[a] Machine and Bin Exterior

Wipe the exterior at least once per week with a clean, soft cloth. Use a damp cloth containing a neutral cleaner to wipe off grease or dirt.

[b] Scoop and Storage Bin Handle Cleaning/Sanitisation (Daily)

1) Either mix 1 litre of water with 4 ml of 5.25% sodium hypochlorite solution in a suitable container, or the recommended Hoshizaki sanitiser as directed.

2) Soak the scoop in the solution for more than 3 minutes. Rinse thoroughly, and shake to remove surplus liquid.

Note: Using a cloth to dry may re-contaminate.

3) Use a neutral cleaner to wash the storage bin handle. Rinse thoroughly.

4) Soak a clean cloth with the sanitising solution, and wipe the handle. Use fresh water and a clean cloth to rinse/dry.

[c] Storage Bin Interior Cleaning/Sanitisation (Weekly)

1) Open the storage bin door, and remove all ice.

2) Wash the bin liner with a neutral non-abrasive cleaner. Rinse thoroughly.

3) Soak a clean cloth with the neutral cleaner, and wipe both sides of the slope and the door inner surface. Wipe off the cleaner with a clean damp cloth.

4) Either mix 5 litres of water with 18 ml of 5.25% sodium hypochlorite solution in a suitable container, or the recommended Hoshizaki sanitiser as directed.

5) Soak a clean sponge or cloth with the solution, and wipe the bin liner, bin door and slope.

6) The remaining solution can be used to sanitise utensils.

Note: Do not wipe dry or rinse after sanitising, but allow to air dry.

[d] Air Filter (Air-Cooled Model Only)

Plastic mesh air filters remove dirt or dust from the air, and keep the condenser from getting clogged. If the filters get clogged, the icemaker's performance will be reduced. Remove and clean the air filter(s) at least twice per month:

1) Slide the air filter off the filter guide [IM-21CNE/30CNE-HC] or the louver [IM-45CNE/45NE/65NE/100CNE/100NE/130NE/240NE-HC].

2) Clean the air filter by using a vacuum cleaner. When severely clogged, use warm water and a neutral cleaner to wash the air filter.

3) Rinse and dry the air filter thoroughly.

NOTICE

After cleaning, be sure to place the air filter back in position.

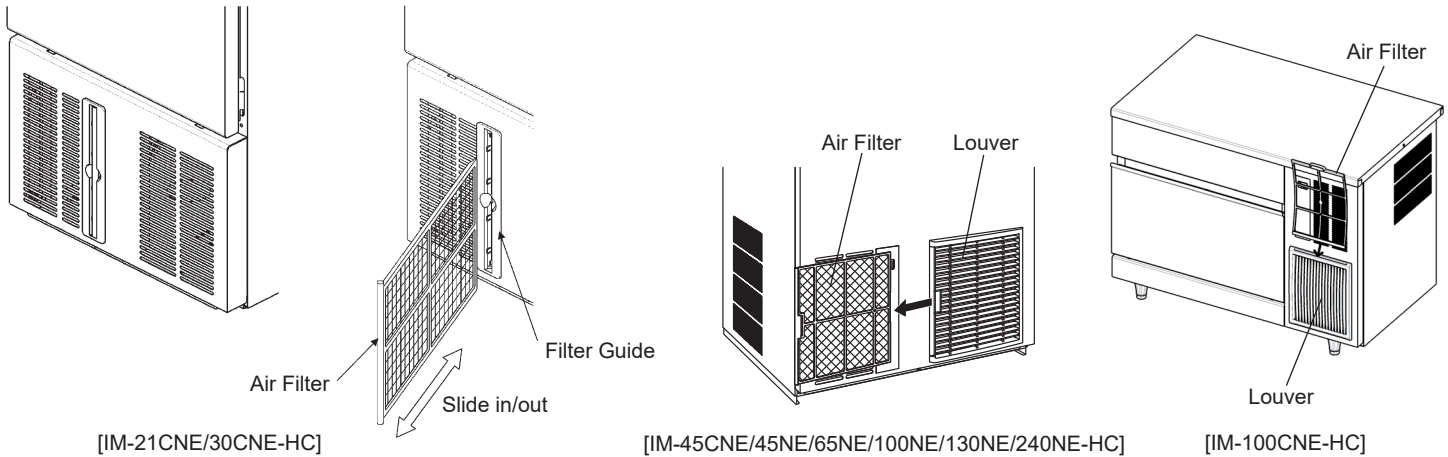

2. BEFORE CALLING FOR SERVICE

⚠ WARNING

Do not damage the refrigerant circuit.

[a] Error Code Indication

⚠ WARNING

If the error code "E" is indicated on the display, there is a possibility of gas leaks. Do not touch the unit. Ventilate the area and immediately call for service.

Code	Possible Cause
E1	Freeze error.
E2	Defrost error.
EE	Other error.
EF	Gas sensor (if provided) detects gas leaks.

[b] No Error Code Indication

If the icemaker does not work properly or does not work at all and no error code is indicated on the display, before calling for service, check that:

- * The power is supplied to the unit.
- * The water is turned on.
- * The air filter is clean (air-cooled model).
- * The cooling water circuit has a proper flow (water-cooled model).

For further assistance or advice, contact your local Hoshizaki service agent.

[c] Alarm Code Indication

If the alarm code A1 or A2 appears, the gas sensor may be defective. Contact your local Hoshizaki service agent.

ENGLISH

3. DISPOSAL

Comply with local regulations regarding disposal of this appliance and its refrigerant gas. Before you scrap the appliance, take off the door to prevent children trapped.

Correct disposal of this product:

This marking indicates that this product should not be disposed with other household wastes throughout the EU. To prevent possible harm to the environment or human health from uncontrolled waste disposal, recycle it responsibly to promote the sustainable reuse of material resources. To return your used device, use the return and collection systems or contact the retailer where the product was purchased. They can take this product for environmental safe recycling.



4. WARRANTY

Hoshizaki warrants to the original owner/user that all Hoshizaki branded products shall be free of defects in material and/or workmanship for the duration of the “warranty period”. The warranty shall be effective for two years from the date of installation. Hoshizaki’s liability under the terms of the warranty are limited and shall exclude routine servicing, cleaning, essential maintenance and/or repairs occasioned by misuse and installations not in accordance with Hoshizaki guidelines.

Warranty repairs should be completed by an approved Hoshizaki dealer or service agency using genuine Hoshizaki components.

To obtain full details of your warranty and approved service agency, please contact your dealer/supplier, or the nearest Hoshizaki Service office:

SPECIFICATIONS

Model	IM-21CNE-HC	IM-30CNE-HC	IM-45CNE-HC
Type	Air-cooled, cube ice	Air-cooled, cube ice	Air-cooled, cube ice
Power Supply	1 phase 220 - 240V 50Hz	1 phase 220 - 240V 50Hz	1 phase 220 - 240V 50Hz
Electric Consumption	225W	230W	275W
Ice Production per 24h	23kg (5mm) / 25kg (15mm) (ambient 10°C, water 10°C)	25kg (5mm) / 30kg (15mm) (ambient 10°C, water 10°C)	40kg (5mm) / 46kg (15mm) (ambient 10°C, water 10°C)
Dimensions	398mm(W) x 451mm(D) x 695mm(H)	398mm(W) x 451mm(D) x 695mm(H)	633mm(W) x 511mm(D) x 690mm(H)
Refrigerant	R290, 55g	R290, 65g	R290, 70g
Insulation Foam Blowing Agent	HFC-free	HFC-free	HFC-free
Weight	Net: 34kg (Gross: 39kg)	Net: 34kg (Gross: 39kg)	Net: 45kg (Gross: 55kg)
Ambient Temp	1 - 40°C	1 - 40°C	1 - 40°C
Water Supply Temp	5 - 35°C	5 - 35°C	5 - 35°C
Water Supply Pressure	0.07 - 0.8 MPa (0.7 - 8 bar)	0.07 - 0.8 MPa (0.7 - 8 bar)	0.07 - 0.8 MPa (0.7 - 8 bar)
Voltage Range	Rated voltage \pm 6%	Rated voltage \pm 6%	Rated voltage \pm 6%

Model	IM-45NE-HC	IM-65NE-HC	IM-100CNE-HC
Type	Air-cooled, cube ice	Air-cooled, cube ice	Air-cooled, cube ice
Power Supply	1 phase 220 - 240V 50Hz	1 phase 220 - 240V 50Hz	1 phase 220 - 240V 50Hz
Electric Consumption	275W	320W	500W
Ice Production per 24h	40kg (5mm) / 46kg (15mm) (ambient 10°C, water 10°C)	52kg (5mm) / 62kg (15mm) (ambient 10°C, water 10°C)	92kg (5mm) / 105kg (15mm) (ambient 10°C, water 10°C)
Dimensions	503mm(W) x 456mm(D) x 840mm(H)	633mm(W) x 506mm(D) x 840mm(H)	1004mm(W) x 600mm(D) x 800mm(H)
Refrigerant	R290, 70g	R290, 110g	R290, 125g
Insulation Foam Blowing Agent	HFC-free	HFC-free	HFC-free
Weight	Net: 44kg (Gross: 50kg)	Net: 50kg (Gross: 60kg)	Net: 77kg (Gross: 88kg)
Ambient Temp	1 - 40°C	1 - 40°C	1 - 40°C
Water Supply Temp	5 - 35°C	5 - 35°C	5 - 35°C
Water Supply Pressure	0.07 - 0.8 MPa (0.7 - 8 bar)	0.07 - 0.8 MPa (0.7 - 8 bar)	0.07 - 0.8 MPa (0.7 - 8 bar)
Voltage Range	Rated voltage \pm 6%	Rated voltage \pm 6%	Rated voltage \pm 6%

Model	IM-100NE-HC	IM-130NE-HC	IM-240NE-HC
Type	Air-cooled, cube ice	Air-cooled, cube ice	Air-cooled, cube ice
Power Supply	1 phase 220 - 240V 50Hz	1 phase 220 - 240V 50Hz	1 phase 220 - 240V 50Hz
Electric Consumption	555W	615W	930W
Ice Production per 24h	92kg (5mm) / 105kg (15mm) (ambient 10°C, water 10°C)	110kg (5mm) / 120kg (15mm) (ambient 10°C, water 10°C)	195kg (5mm) / 210kg (15mm) (ambient 10°C, water 10°C)
Dimensions	704mm(W) x 506mm(D) x 1200mm(H)	704mm(W) x 506mm(D) x 1200mm(H)	704mm(W) x 665mm(D) x 1510mm(H)
Refrigerant	R290, 120g	R290, 120g	R290, 147g
Insulation Foam Blowing Agent	HFC-free	HFC-free	HFC-free
Weight	Net: 76kg (Gross: 84kg)	Net: 76kg (Gross: 84kg)	Net: 111kg (Gross: 122kg)
Ambient Temp	1 - 40°C	1 - 40°C	1 - 40°C
Water Supply Temp	5 - 35°C	5 - 35°C	5 - 35°C
Water Supply Pressure	0.07 - 0.8 MPa (0.7 - 8 bar)	0.07 - 0.8 MPa (0.7 - 8 bar)	0.07 - 0.8 MPa (0.7 - 8 bar)
Voltage Range	Rated voltage \pm 6%	Rated voltage \pm 6%	Rated voltage \pm 6%

ENGLISH

Model	IM-30CWNE-HC	IM-45WNE-HC	IM-65WNE-HC
Type	Water-cooled, cube ice	Water-cooled, cube ice	Water-cooled, cube ice
Power Supply	1 phase 220 - 240V 50Hz	1 phase 220 - 240V 50Hz	1 phase 220 - 240V 50Hz
Electric Consumption	190W	240W	300W
Ice Production per 24h	27kg (5mm) / 30kg (15mm) (ambient 10°C, water 10°C)	42kg (5mm) / 45kg (15mm) (ambient 10°C, water 10°C)	51kg (5mm) / 60kg (15mm) (ambient 10°C, water 10°C)
Dimensions	398mm(W) x 451mm(D) x 695mm(H)	503mm(W) x 456mm(D) x 840mm(H)	633mm(W) x 506mm(D) x 840mm(H)
Refrigerant	R290, 70g	R290, 90g	R290, 110g
Insulation Foam Blowing Agent	HFC-free	HFC-free	HFC-free
Weight	Net: 35kg (Gross: 41kg)	Net: 45kg (Gross: 53kg)	Net: 53kg (Gross: 63kg)
Ambient Temp	1 - 40°C	1 - 40°C	1 - 40°C
Water Supply Temp	5 - 35°C	5 - 35°C	5 - 35°C
Water Supply Pressure	0.07 - 0.8 MPa (0.7 - 8 bar)	0.07 - 0.8 MPa (0.7 - 8 bar)	0.07 - 0.8 MPa (0.7 - 8 bar)
Voltage Range	Rated voltage \pm 6%	Rated voltage \pm 6%	Rated voltage \pm 6%

Model	IM-100WNE-HC	IM-130WNE-HC	IM-240WNE-HC
Type	Water-cooled, cube ice	Water-cooled, cube ice	Water-cooled, cube ice
Power Supply	1 phase 220 - 240V 50Hz	1 phase 220 - 240V 50Hz	1 phase 220 - 240V 50Hz
Electric Consumption	465W	550W	810W
Ice Production per 24h	80kg (5mm) / 90kg (15mm) (ambient 10°C, water 10°C)	100kg (5mm) / 110kg (15mm) (ambient 10°C, water 10°C)	190kg (5mm) / 205kg (15mm) (ambient 10°C, water 10°C)
Dimensions	704mm(W) x 506mm(D) x 1200mm(H)	704mm(W) x 506mm(D) x 1200mm(H)	704mm(W) x 665mm(D) x 1510mm(H)
Refrigerant	R290, 147g	R290, 147g	R290, 147g
Insulation Foam Blowing Agent	HFC-free	HFC-free	HFC-free
Weight	Net: 74kg (Gross: 82kg)	Net: 74kg (Gross: 82kg)	Net: 120kg (Gross: 131kg)
Ambient Temp	1 - 40°C	1 - 40°C	1 - 40°C
Water Supply Temp	5 - 35°C	5 - 35°C	5 - 35°C
Water Supply Pressure	0.07 - 0.8 MPa (0.7 - 8 bar)	0.07 - 0.8 MPa (0.7 - 8 bar)	0.07 - 0.8 MPa (0.7 - 8 bar)
Voltage Range	Rated voltage \pm 6%	Rated voltage \pm 6%	Rated voltage \pm 6%

Note: The above specifications are for the representative models.

Архангельск (8182)63-90-72
Астана (7172)727-132
Астрахань (8512)99-46-04
Барнаул (3852)73-04-60
Белгород (4722)40-23-64
Брянск (4832)59-03-52
Владивосток (423)249-28-31
Волгоград (844)278-03-48
Вологда (8172)26-41-59
Воронеж (473)204-51-73
Екатеринбург (343)384-55-89
Иваново (4932)77-34-06

Ижевск (3412)26-03-58
Иркутск (395)279-98-46
Казань (843)206-01-48
Калининград (4012)72-03-81
Калуга (4842)92-23-67
Кемерово (3842)65-04-62
Киров (8332)68-02-04
Краснодар (861)203-40-90
Красноярск (391)204-63-61
Курск (4712)77-13-04
Липецк (4742)52-20-81
Киргизия (996)312-96-26-47

Магнитогорск (3519)55-03-13
Москва (495)268-04-70
Мурманск (8152)59-64-93
Набережные Челны (8552)20-53-41
Нижний Новгород (831)429-08-12
Новокузнецк (3843)20-46-81
Новосибирск (383)227-86-73
Омск (3812)21-46-40
Орел (4862)44-53-42
Оренбург (3532)37-68-04
Пенза (8412)22-31-16
Казахстан (772)734-952-31

Пермь (342)205-81-47
Россия (495)268-04-70
Ростов-на-Дону (863)308-18-15
Рязань (4912)46-61-64
Самара (846)206-03-16
Санкт-Петербург (812)309-46-40
Саратов (845)249-38-78
Севастополь (8692)22-31-93
Симферополь (3652)67-13-56
Смоленск (4812)29-41-54
Сочи (862)225-72-31
Ставрополь (8652)20-65-13

Сургут (3462)77-98-35
Тверь (4822)63-31-35
Томск (3822)98-41-53
Тула (4872)74-02-29
Тюмень (3452)66-21-18
Ульяновск (8422)24-23-59
Уфа (347)229-48-12
Хабаровск (4212)92-98-04
Челябинск (351)202-03-61
Череповец (8202)49-02-64
Ярославль (4852)69-52-93

<https://hoshizaki.nt-rt.ru/> || hzo@nt-rt.ru